



Xerox 6050A Wide Format

6050AWFP2R – GAP
6050AWFP4R – GAH

September 14,
2007

PRODUCT RANGE / POSITIONING

The Xerox 6050A Wide Format Printer is a mid-volume system with a variety of options. Two speeds are offered, 7&9 D/minute, all models require a FreeFlow™ Accxes™ Controller.

Printer models can be configured as Wide Format Copy Systems with the Xerox Wide Format Scanner (Synergix Scan System).

The 6050A is intended for use as a network printer and a walk-up copier. The expected AVERAGE monthly volume is 6,000-10,000 linear feet (17,500-29,000 square feet). The estimated maximum monthly volume is 120K - 150K linear feet (based on an 8 hr day, 5 days a week, 4.2 weeks a month minus projected service activities)

AVAILABLE CONFIGURATIONS

Model	Speed	# of Rolls	Product Code
6050A Printer (WFP) 2R	7-9D/min	2	GAP
6050A Printer (WFP) 4R	7-9D/min	4	GAH

Note: the 6050A Pinter can be configured as a Wide Format Copy System with the addition of a Wide Format Scanner (Prod. Code PKU)

PERFORMANCE

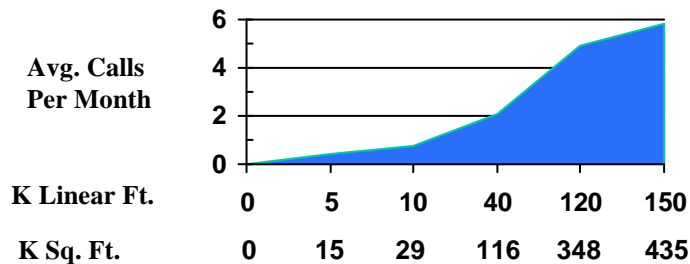

OPTIONS

The following options are available:

- Multi-Sheet Insertion (MSI) – provides manual bypass feeding capabilities for cut-sheet media (Product code TUE)
- High-Capacity Stacker – Stacks up to 750 D-size prints (product code UHE)
- Folder Enablement Kit – Provides a serial connection to an online folder using the Generic Finisher Interface (GFI) (Product code UEV)

Note: Drawer/Roll upgrades are not available.

NOTE: The above estimated Performance Data is based on Product testing and field service data. The individual machine performance may vary therefore service call frequency can not be guaranteed.



Xerox 6050A Wide Format

6050AWFP2R – GAP
6050AWFP4R – GAH

September 14,
2007

SPECIAL CONSIDERATIONS

Print Stacking – Standard printer output tray capacity up to 100 D/A1 size prints (Bond Media)

Document Stacking (6050AWF Copy System) – Document tray capacity up to 100 D/A1 size documents (Bond Media, Good Condition)

Meter – A linear meter and area meter are provided. Meters to read in feet (linear) & square feet or meters (linear) & square meters. Units selectable by the installing CSE.

Color Scanning – Color scanning is supported with the Wide Format Scanner (Product Code PKU)

PRINT THROUGHPUT MATERIAL

Bond	Unlimited use with no reliability degradation: <ul style="list-style-type: none">•20 lb. Xerox Premium 500 ft. (US)•20 lb. Xerox Performance 500 ft. (US)•75 g/m² Premium Bond•75 g/m² Performance Bond
Vellum	Up to 10% of monthly print volume with no reliability degradation: <ul style="list-style-type: none">•20 lb Performance HPH Vellum
Film	Up to 10% of monthly print volume with no reliability degradation: <ul style="list-style-type: none">•Accu-Image Elite Film 4 MIL
Roll Size	11” through 36” wide, 3” core, outside diameter up to 6.9” <i>(Roll media taped to the core is required for automatic roll switching)</i>
Manual Feed (Optional)	Optional Multi-Sheet Inserter (MSI) handles cut-sheet Bond media 11” to 36” wide. Handles 70 sheets up to 12x18”, single sheets up to 36x48”



Xerox 6050A Wide Format

6050AWFP2R – GAP
6050AWFP4R – GAH

September 14,
2007

OUTPUT SPECIFICATIONS

Minimum (Roll Feed):	11 x 8.5" (A4 297x210mm) Landscape
(Optional MSI):	8.5 x 11" (A4 210x297mm) Portrait
Maximum:	36" x 49.2' (914mm x 15m)
Magnification (size-for-size):	100% \pm 0.4%
Cut Length Accuracy:	\pm 2mm (0.08") for lengths up to 24" (610mm) \pm 3mm (0.12") for lengths greater than 24" (610mm)
Lead- and Trail-edge Deletions:	<3mm (0.12")
Side-edge Deletion:	<3mm (0.12")

6050A Controller Specifications

Controller Description

The 6050A printers require a FreeFlow™ Accxes™ Controller. The Controller manages printing and copying functions. The Controller is not integrated into the printer, and requires additional space and electrical considerations.

Please refer to the FreeFlow™ Accxes™ Controller Product Fact Sheet for requirements concerning:

Controller Hardware
CPU, Memory, Hard Disk Drive, Interfaces
Controller Options
Controller Software
Supported File Formats
Drivers & Client Software



Xerox 6050A Wide Format

6050AWFP2R – GAP
6050AWFP4R – GAH

September 14,
2007

SPEED

PRINT SPEEDS (7 D's/minute)

US Media			EO Media		
Size	LEL ppm	SEL ppm	Size	LEL ppm	SEL ppm
A	15.2	9.6	A	15.5	10.0
B	12.6	9.6	B	13.3	10.0
C	9.6	6.9	C	10.0	7.3
D	6.9	4.7	D	7.3	4.9
E	3.0	3.0	E	3.1	3.1

Architectural Sizes *ANSI Sizes*

PRINT SPEEDS (9 D's/minute)

US Media			EO Media		
Size	LEL ppm	SEL ppm	Size	LEL ppm	SEL ppm
A	19.4	11.4	A4	15.6	10.2
B	15.8	11.4	A3	12.9	10.2
C	11.4	9.0	A2	10.2	7.0
D	9.0	6.2	A1	7.0	5.0
E	4.8	4.8	A0	3.0	3.0

Architectural Sizes *ANSI Sizes* *ISO Sizes*

OTHER

First Copy Out Time: 19 seconds (Roll 1, E/A0 size)

First Print Out Time: 32 seconds (Roll 1, E/AO size,)

Warm-Up Time: 3 minutes

Scan Speed – Please refer to Synergix Scan System
Product Fact Sheet for additional requirements



Xerox 6050A Wide Format

6050AWFP2R – GAP
6050AWFP4R – GAH

September 14,
2007

NORTH AMERICA CUSTOMER SUPPORT

Supplies 1-800-822-2200

United States Service/Customer Support 1-800-821-2797

Canada Service/Customer Support 1-800-939-3769

Canada Supplies 1-800-668-0199

Online Support and Downloads:

<http://www.service.xerox.com/go/productselect.asp>

REFERENCE MATERIAL

- 6050A Printer User Guide 701P47273*
- 6050A Copier/Printer User Guide 701P45100*
- FreeFlow™ Accxes™ Software Tools Customer Training Guide for AccXES Firmware 12.5 701P43787*
- *You cannot order these separately. They are located on 6030/6050/6050A SGS or FFA System Doc CD.
- FreeFlow™ Accxes™ Controller (FRX) Product Fact Sheet
- Synergix Scan System Product Fact Sheet
- Material Safety Data Sheets are available online:
http://www.xerox.com/go/xrx/template/020e.jsp?Xcentry=USA&Xlang=en_US
- Safety Phone Number: 1-800-828-6571

NORTH AMERICA SUPPLIES

Item	Reorder Number	Units/Ctn	Expected Life
Toner	6R1185	1	23,500 Square Ft.** ** 5% Area Coverage
Waste Bottle		1	39,000 Lin. Ft.

Note: Waste Toner bottle is a service replaceable item, No customer orderable part number is available



Xerox 6050A Wide Format

6050AWFP2R – GAP
6050AWFP4R – GAH

September 14,
2007

SPACE, ELECTRICAL & ENVIRONMENTAL REQUIREMENTS

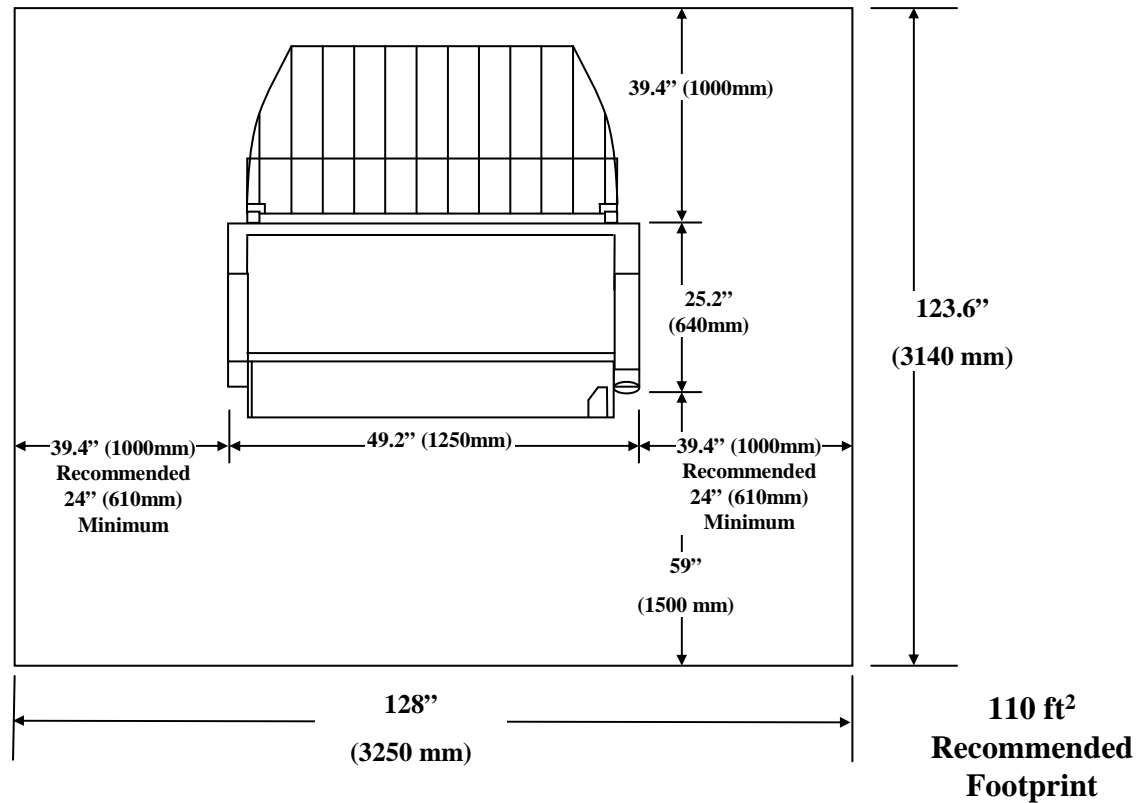

Floor Space Requirements

Printer Model shown. Please refer to the Synergix Scan System Product Fact Sheet for additional requirements (Wide Format Copy System Configuration)



Xerox 6050A Wide Format

6050AWFP2R – GAP
6050AWFP4R – GAH

September 14,
2007

SPACE, ELECTRICAL & ENVIRONMENTAL REQUIREMENTS

Space Requirements

Height	84" (2135mm) Clearance from floor to nearest overhead obstruction within the floor space requirement.
Width	128" (3250mm) Recommended 97.2" (2470mm) Minimum
Depth	123.6" (3140mm)

Machine Dimensions

Height	37" (940mm)
Width	49.2" (1250mm)
Depth	25.2" (640mm)

Machine Weight

Weight (WFP)

6050A (2Roll)	560lb (254kg)
<i>Ship Weight</i>	<i>681lb (309kg)</i>
6050A (4 Roll)	670lb (304kg)
<i>Ship Weight</i>	<i>871lb (359kg)</i>

Floor Loading: *The load on a foot shall be 45% or less of the total weight when the machine is placed on a horizontal floor.*

Other Specifications

Heat Emission	1706 BTU (Standby) 8532 BTU (Running)
Audible Noise	(Running) 76 dba (Max) (Standby) 57 dba (Max)

Environmental Requirements

Temperature Range	50-89 °F (10-32° C)
Humidity	15-85% RH

Moveability

Once installed, this machine is not considered moveable. If moved, releveling of the machine will be required.



Xerox 6050A Wide Format

6050AWFP2R – GAP
6050AWFP4R – GAH

September 14,
2007

SPACE, ELECTRICAL & ENVIRONMENTAL REQUIREMENTS

Electrical Requirements

Power Requirements

Printer	Voltage	208-240 VAC \pm 10%
	Current	12.0 A

One 20A circuit is required

Controller	Voltage	110/220 VAC \pm 10%
	Current	1.0 A Max

Frequency 50 / 60 Hz

Power Consumption

Printer	Standby	500 W
	Running	3.2 KW (or less)

Controller	Standby	60 W
	Running	60 W (or less)

Please refer to the Synergix Scan System Product Fact Sheet for additional requirements (Wide Format Copy System Configuration)

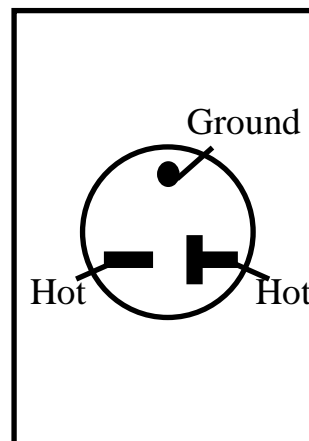

6050A

**NEMA 6-20R Receptacle for
Printer**

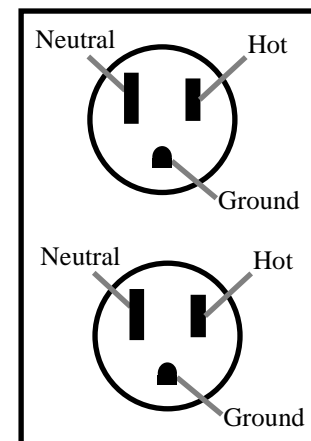

North America

NEMA 5-15R Receptacle

**Single for FreeFlow™
Accxes™ Controller only**

**Duplex for use as a Wide
Format Copy System**